

SC 40RE

Scanjet tank cleaning equipment

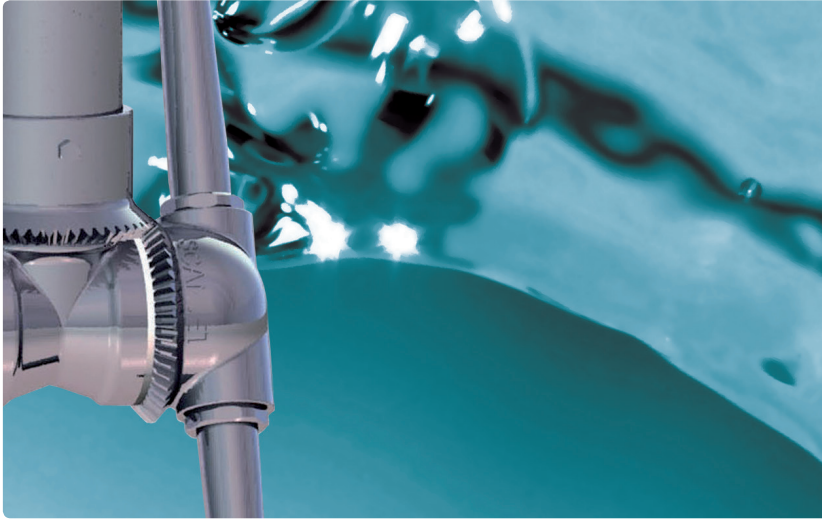

KEY FEATURES

- + Removable drive
- + Easy installation
- + Controllable rotation
- + 2 & 4 nozzle design
- + Very low pressure drop
- + Quiet operation
- + CE rated
- + Self draining

The SC 40RE is an electric driven externally powered automated tank cleaning machine. Both 2 nozzle and 4 nozzle versions are available with all wetted parts constructed of 316 stainless steel and other highly corrosion resistant materials.

As none of the cleaning fluid is used to power the SC 40RE, the pressure drop across the machine is very minimal. As a result, the fluid energy from the cleaning supply pump is maximized.

The SC 40RE is a very rugged and durable tank cleaning machine; designed for demanding cleaning applications where reliability and long service intervals are required.

Quality Standards

The SC 40RE is produced in accordance with ISO 9001 Quality Standards and our certificate of conformity and accreditation is available on request.

Additionally, the SC40RE conforms to United States ASME standards for construction and others are available upon request.

Typical applications

- + Ethanol storage and process tanks
- + Paints and coatings process vessels
- + Over-the-road tankers and railcars
- + Totes and IBC's
- + Batch blending tanks



Technical performance

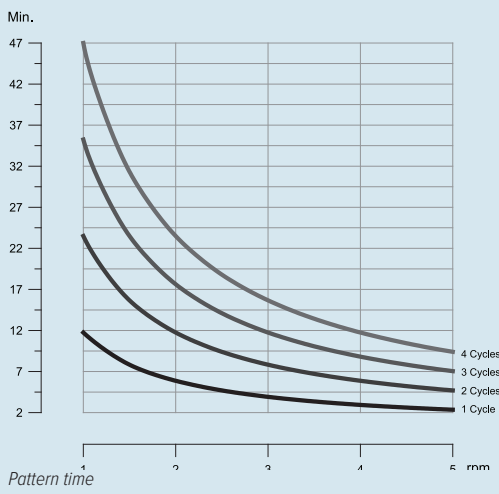
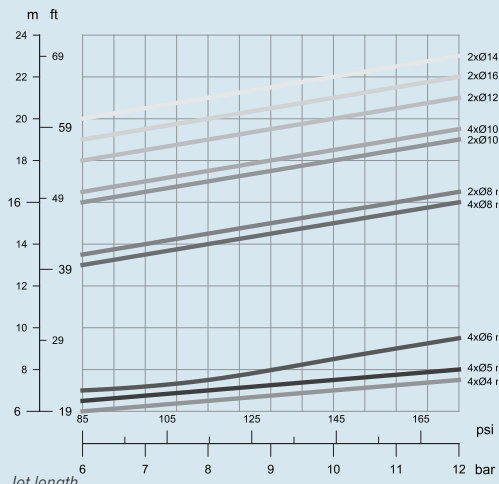
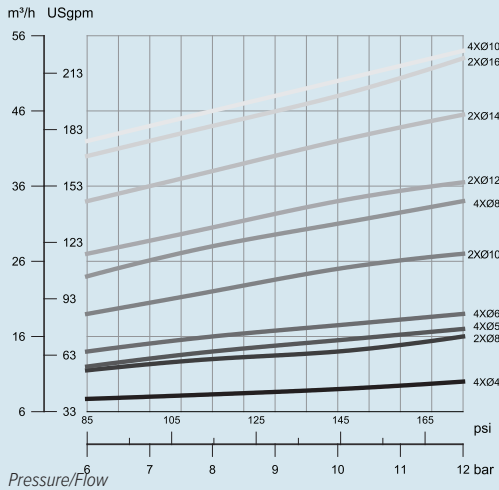

Dimensions

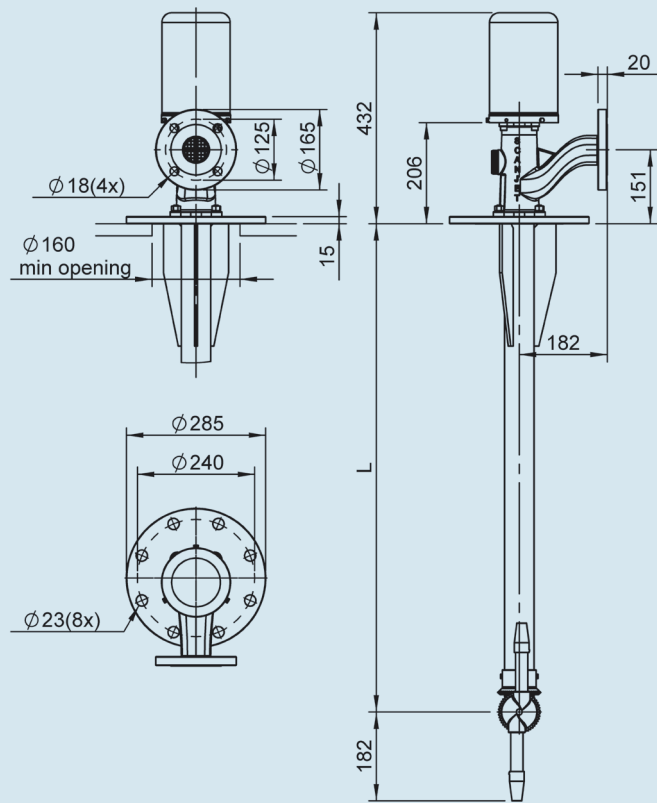

Specifications

Flow	5-55 m³/h
Inlet pressure	0,6-1,2 MPa
Max pressure	1,4 MPa
Recommended pressure	0,8 MPa
Max temperature	95°C
Rotation speed	1-5 rpm
Standard length	1500 mm
Weight	38 kg
Per additional meter of main pipe	10 kg
Tank connection	PN16 DN150
Inlet connection	PN16 DN50
Materials	AISI 316, PTFE, Viton
Lubrication	Cleaning Media
Drive unit	Electric engine



Scanjet Systems AB
P.O. Box 9316
SE-400 97 Göteborg Sweden
Phone + 46 31 338 75 30
Fax + 46 31 338 75 40
E-mail sales@scanjetsystems.com
Web www.scanjetsystems.com